

IT'S A WONDERFUL TOY...

IT'S

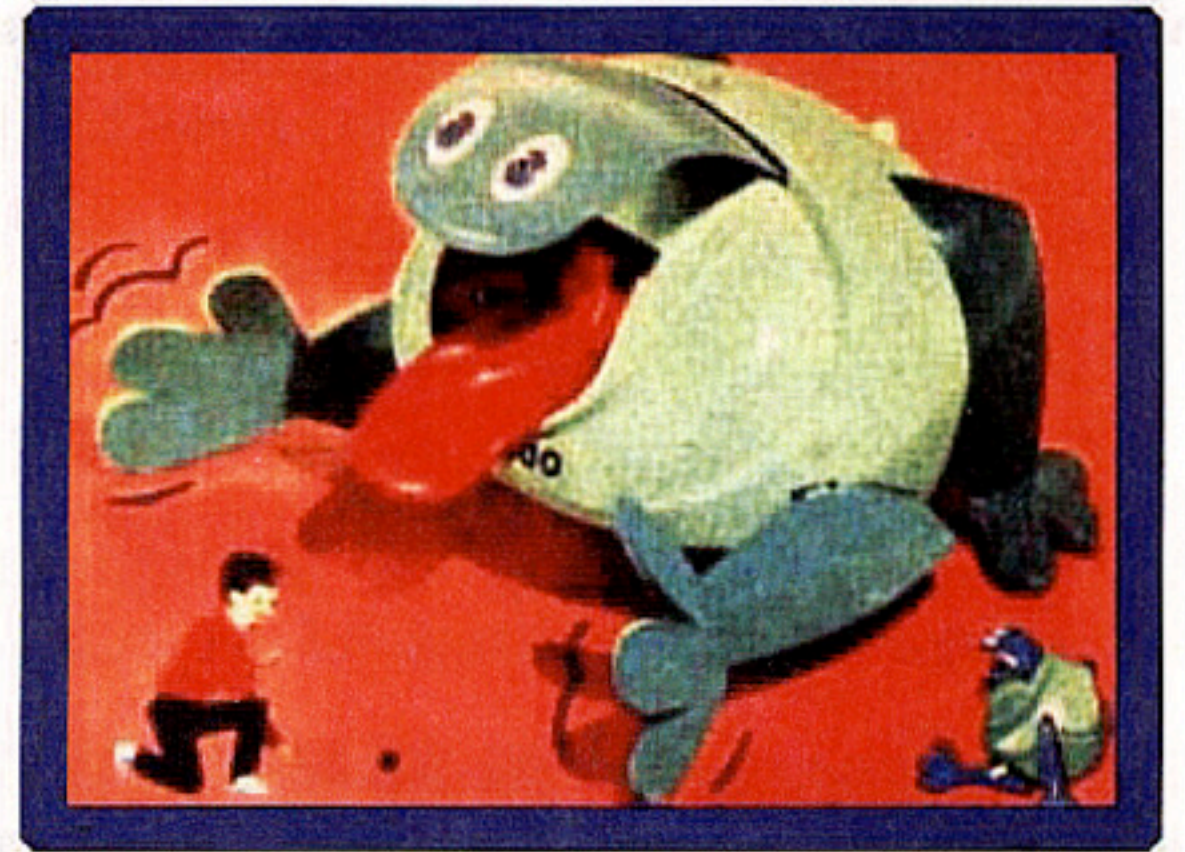

SERVICE CHECK LIST AND REPAIR MANUAL

ROBOT COMMANDO

SERVICE CHECK LIST

This CHART is a guide to help you correct any problems that may occur with the ROBOT COMMANDO.

IMPORTANT: We had discovered that a great number of consumers are not operating the ROBOT COMMANDO correctly. Therefore: **BEFORE ANY ADJUSTMENTS ARE MADE IN THE TOY, BLOW SHARPLY INTO MICROPHONE TO START. VOICE COMMANDS WILL OPERATE ROBOT ONLY IF ONE'S BREATH PUSHES FLIPPER MECHANISM DOWN.**

PROBLEM	SUGGESTED REMEDY
(1) Toy does not operate at all (motor does not run).	<p>A. Check batteries for life or power, replace with new ones if necessary. (Set knob on forward to start.)</p> <p>B. Batteries should all face in same direction as shown by arrows in base.</p> <p>C. Check control cable plug in bottom of base to be sure it is tight against the two contact prongs of base. (Make sure metal strap over plug is screwed down tight.)</p> <p>D. Be sure that the on-off switch of microphone is in the "on" position and that the metal flipper inside of microphone is in the down position. The flipper is depressed down by blowing sharply into mike. <u>Do not</u> use any tool to depress flipper.</p> <p>E. To check Robot without microphone, touch each end of a hairpin or paper clip to the ends of the two metal contacts to which the cable plug is fastened. If the motor runs, the fault is with the control unit. Replace control unit. (Instruction sheet for replacement of control unit on separate sheet.)</p>
(2) If knob on handle is tight to turn.	<p>A. Check for kinks of inner cable wire, replace entire unit if kink cannot be straightened.</p>
(3) Robot runs, but knob of handle does not govern action of toy.	<p>A. Check to see if small metal ring at end of inner metal cable wire is over small pin of movable black slide in bottom of toy.</p>
(4) Robot only runs when microphone cable is held in certain positions.	<p>A. Replace cable unit.</p>
(5) Robot does not move or turn as it should.	<p>A. Replace cable unit.</p> <p>B. Remove hub disk on wheel with screwdriver or any other similar tool and, if spring on shaft is not compressed, push nut further in to compress spring. Replace hub.</p>
(6) Robot stops in fire missile position or arms do not turn at all.	<p>A. Replace batteries with fresh ones.</p>
(7) Arms turn very slowly and do not throw missiles.	<p>A. This requires removing hub nut from arm and re-positioning of arm. Best done at factory.</p>
(8) Rocket launch mechanism does not cock or catch.	<p>A. Press down very hard and sharp. Repeat several times if necessary.</p>
(9) Rocket mechanism does not fire after being loaded. Warning: Keep face away from hat launch area.	<p>A. Straighten cable out to full length.</p> <p>B. <u>May</u> be corrected by removing small panel on side (panel is removed by taking out small screw on right side) of Robot and pushing rocket mechanism arm up to release (repeat 3 or 4 times).</p> <p>C. Replace cable unit.</p>
(10) Eyes do not turn.	<p>A. Remove left side panel and check elastic string to be certain it rides in pulleys.</p>
(11) Broken head piece.	<p>A. Replace with new hat. Squeeze end of hat together to fit over the two pins on body.</p>
(12) Indicator on handle does not line up exactly opposite dots for all operations.	<p>A. Indicator pointer is used to show <u>approximate</u> locations for operations. It need not line up exactly opposite dots to perform these operations. It may be necessary to move pointer as much as 1/4" away from dot. This will in no way effect the Robot's performance.</p> <p>B. On missile fire it is sometimes necessary to wait a few seconds before the arms begin to operate. The hub nuts on arms can be watched to make sure arm shaft is turning.</p>



ROBOT COMMANDO™

PATENT PENDING

Manufactured in U.S.A. by Ideal Toy Corp., Hollis 23, N. Y.

NO. 4805-8

OPERATING INSTRUCTIONS

WARNING: IN HANDLING YOUR ROBOT COMMANDO DO NOT KINK OR TWIST VOICE CONTROL MIKE WIRE.

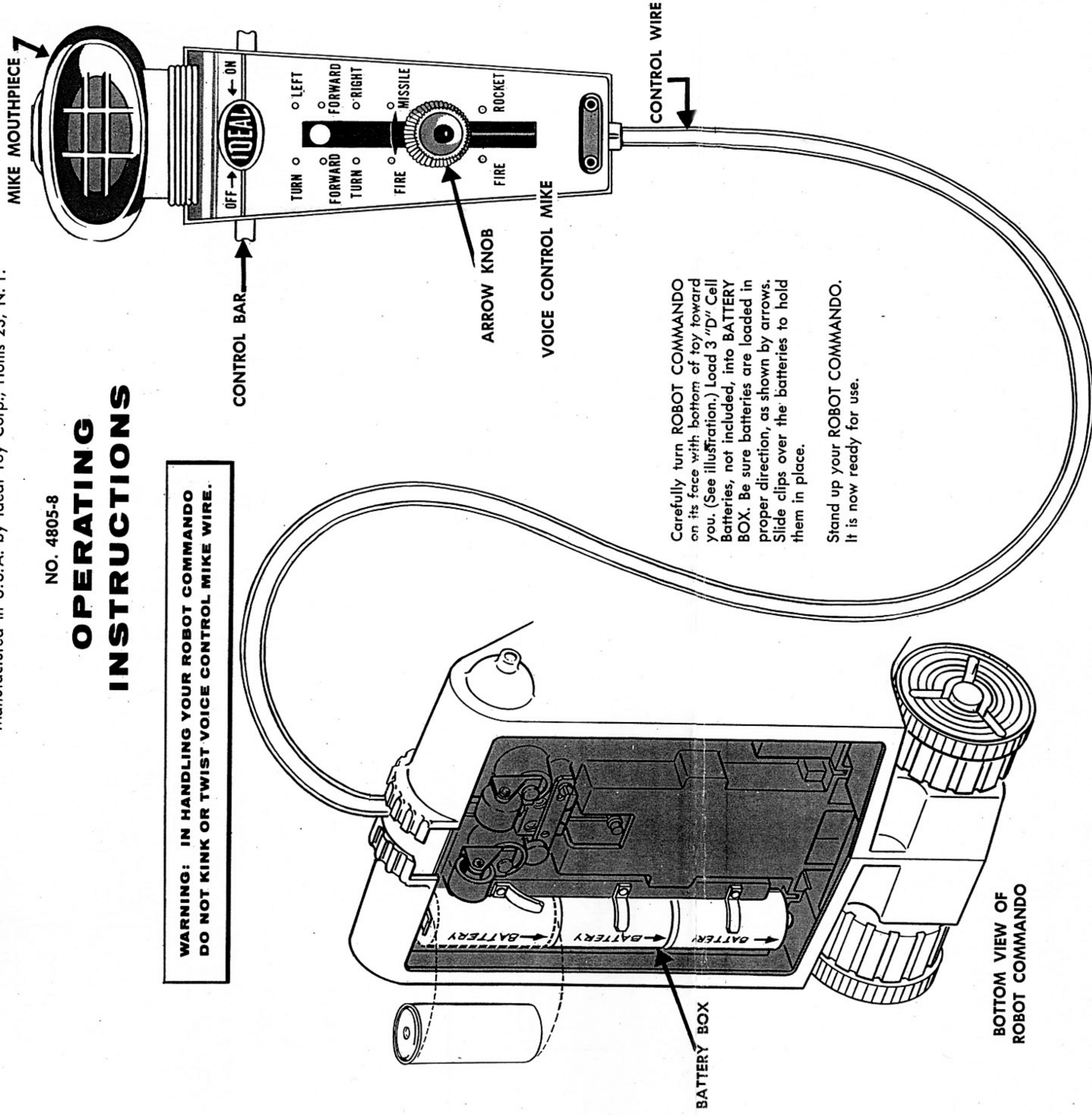

LOAD MISSILES.
Drop 4 BALL MISSILES into the shoulder pad of each arm.

MISSILES



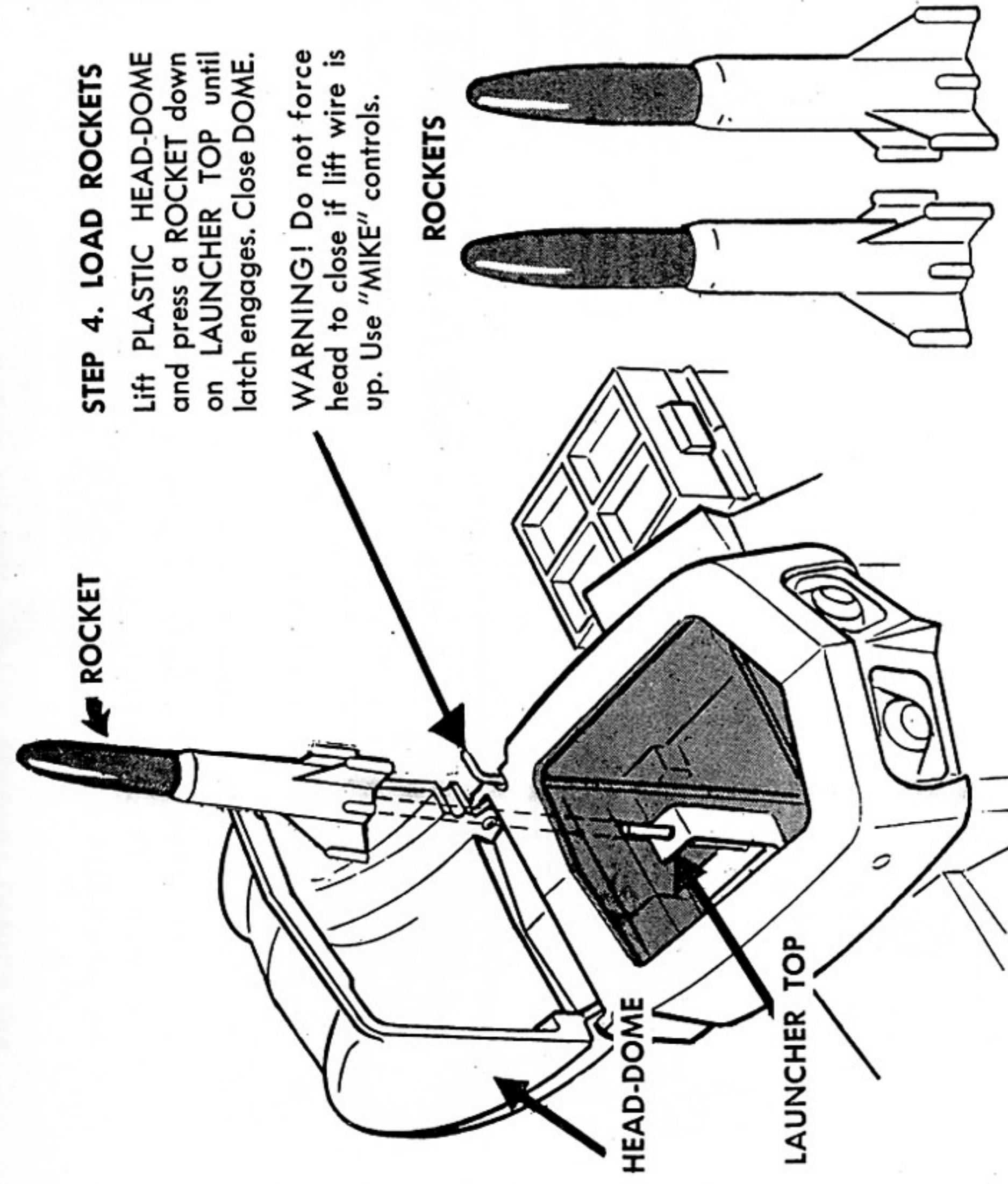

STEP 4. LOAD ROCKETS

Lift PLASTIC HEAD-DOME and press a ROCKET down on LAUNCHER TOP until latch engages. Close DOME.

WARNING! Do not force head to close if lift wire is up. Use "MIKE" controls.

ROCKETS

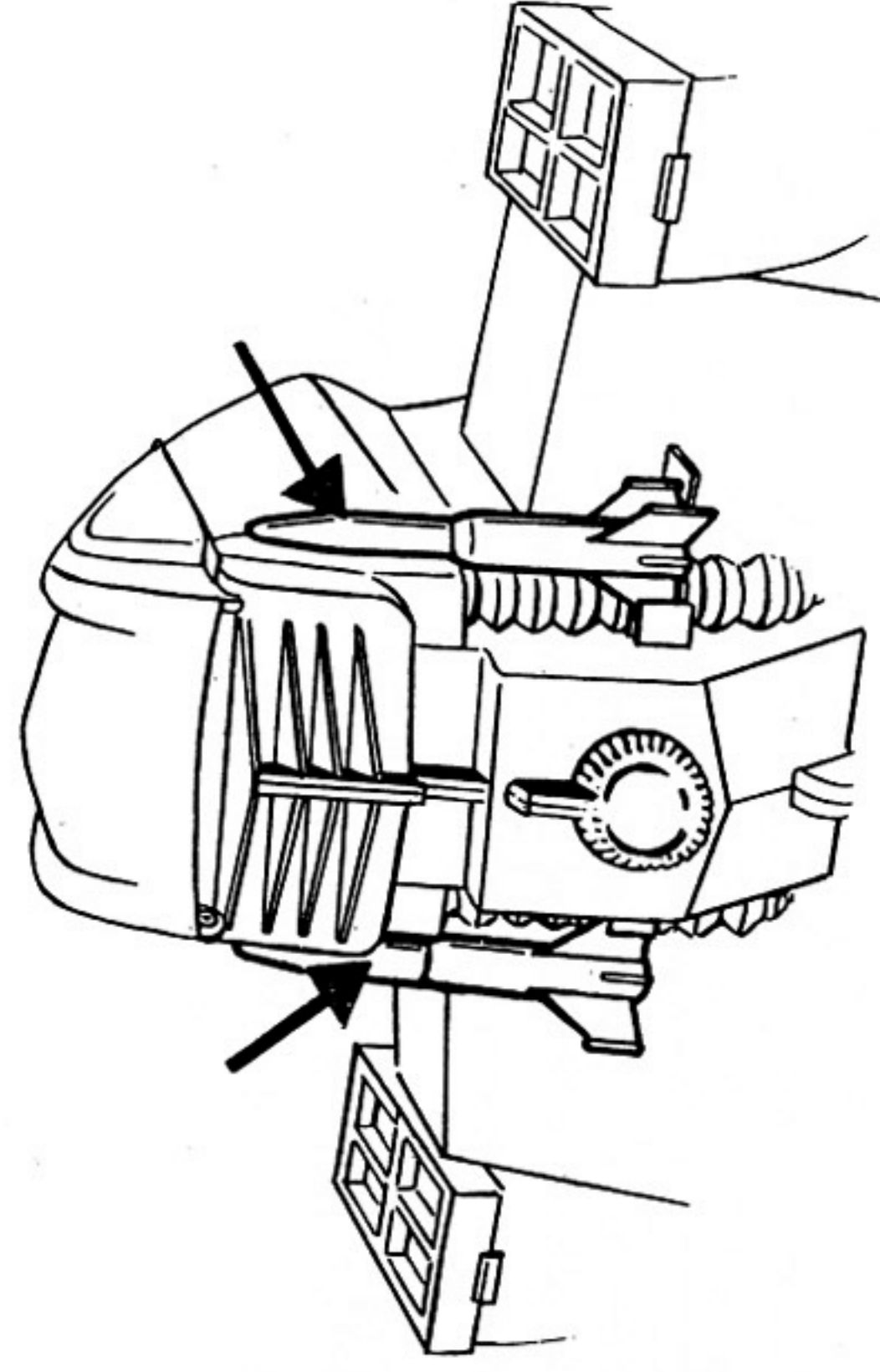

Store ROCKETS on back of ROBOT COMMANDO Shoulders as illustrated.

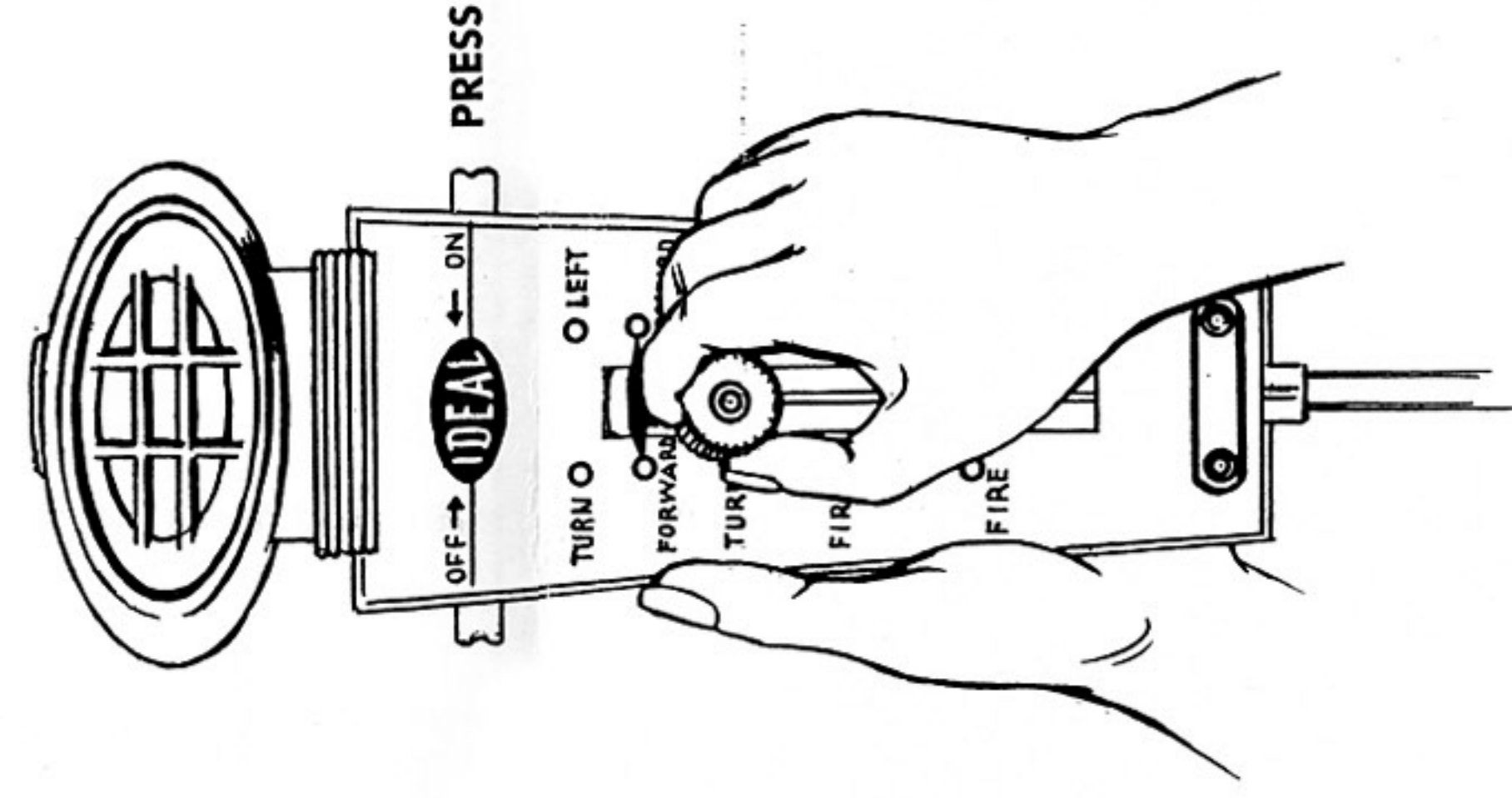

STEP 5. OPERATIONS.

ROBOT COMMANDO obeys your command! Set the control for forward, right turn, left turn, rocket or missile fire by rotating the ARROW KNOB. Press in the CONTROL BAR to "ON" position and speak command into MIKE, blowing outward on first letter of each of the following expressions:

TTTTURN LEFT
TTTTURN RIGHT
FFFORWARD
FFFIRE MISSILE
FFFIRE ROCKET

For example: Rotate ARROW KNOB to Forward position. Hold MIKE no more than 3 inches away from mouth and say FFForward into the MIKE MOUTHPIECE. Accent the "F" sound so that air pressure hits into the MIKE MOUTHPIECE. Rotate the ARROW KNOB clockwise or counter clockwise for other commands. To stop the robot action press in CONTROL BAR to "OFF" position of MIKE.

NOTICE.

To operate completely by voice the CONTROL BAR should be pushed to "OFF" position between each operation. **WARNING:** If ARROW KNOB is difficult to move up or down, turn mechanism on by voice command and shift KNOB until free.

ROBOT may also be controlled mechanically without start-stop action by leaving CONTROL BAR in "ON" position. Give your first voice command; then continue moving ARROW KNOB up and down to the different positions without using words. Missile firing arms are engineered for use with CONTROL MIKE. Do not force them in any way.

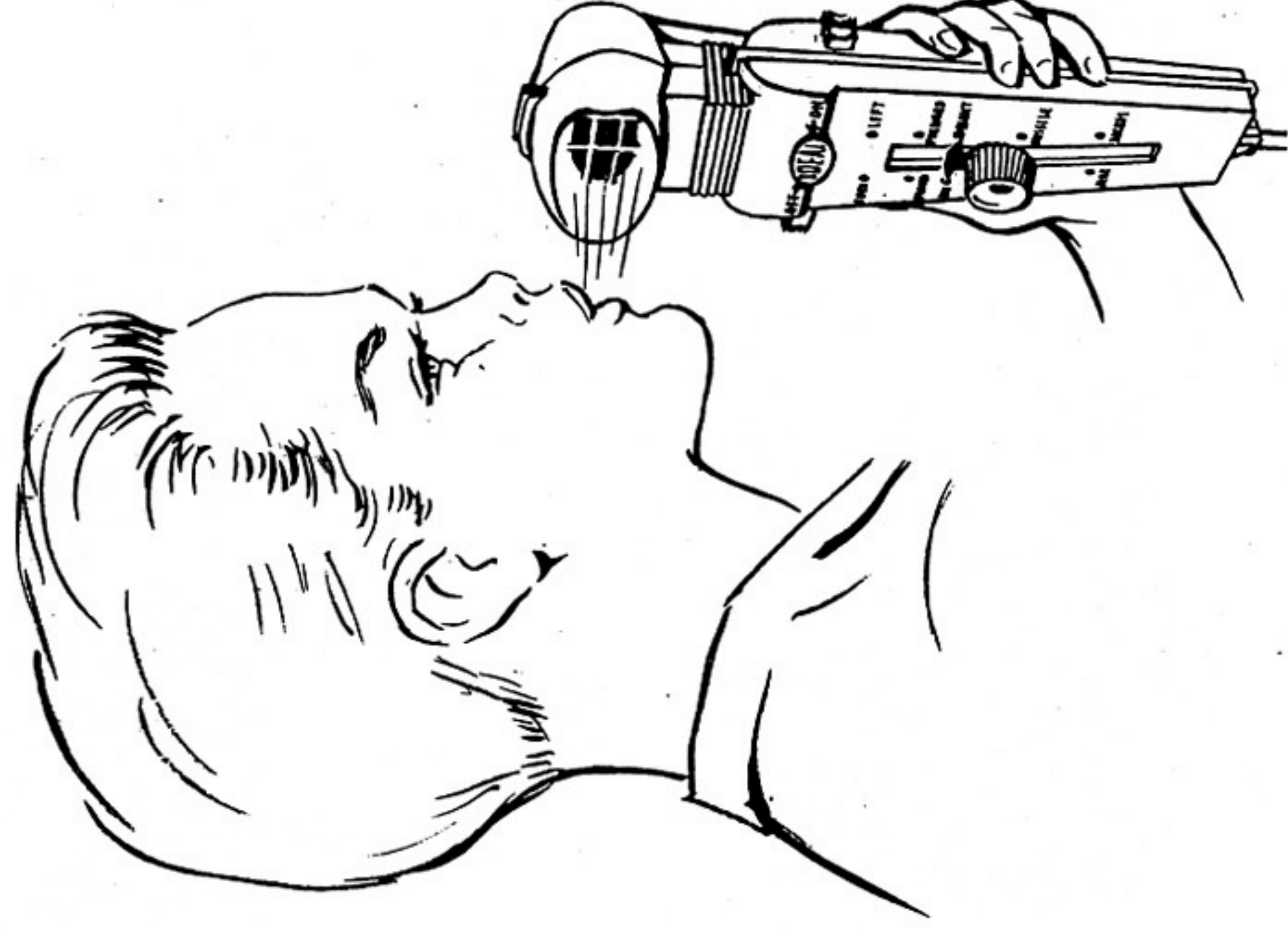

SHOULD YOUR ROBOT COMMANDO FAIL TO OPERATE, CHECK BATTERIES TO SEE IF THEY ARE FACING IN PROPER DIRECTION AND MAKING CONTACT. IT IS POSSIBLE FOR A BATTERY TO BE FAULTY; REPLACE EACH BATTERY IN ROTATION WITH ANOTHER ONE TO ELIMINATE THIS POSSIBILITY. TO PROLONG BATTERY LIFE BE SURE "VOICE CONTROL" MIKE IS IN STOP POSITION WHEN TOY IS NOT IN USE. BATTERIES WILL LAST LONGER IF TOY IS NOT RUN ON CARPETED SURFACES.

IMPORTANT

Please refer to SERVICE CHECK LIST to see if mal-function of Robot can be corrected before attempting any of the following repairs.

IF ROCKET MECHANISM WILL NOT COCK TO FIRE

A. Remove Right Inspection panel

B. Look up into the inspection hole towards the head of the Robot and check to see if Rocket Trigger mechanism is as follows:

1. See if metal frame Foot is bent slightly DOWN. (see drawing "A") If so, press UP on foot until it is parallel to trigger foot. (see drawing "B") Test mechanism to see if fault has been corrected.

2. See if metal frame Foot is bent slightly UP. (see drawing "C") If so, insert tip of a stubby screwdriver between metal frame Foot and and trigger foot and twist slightly. Test mechanism to see if fault has been corrected.

REASSEMBLY

A. Replace Right Inspection Panel

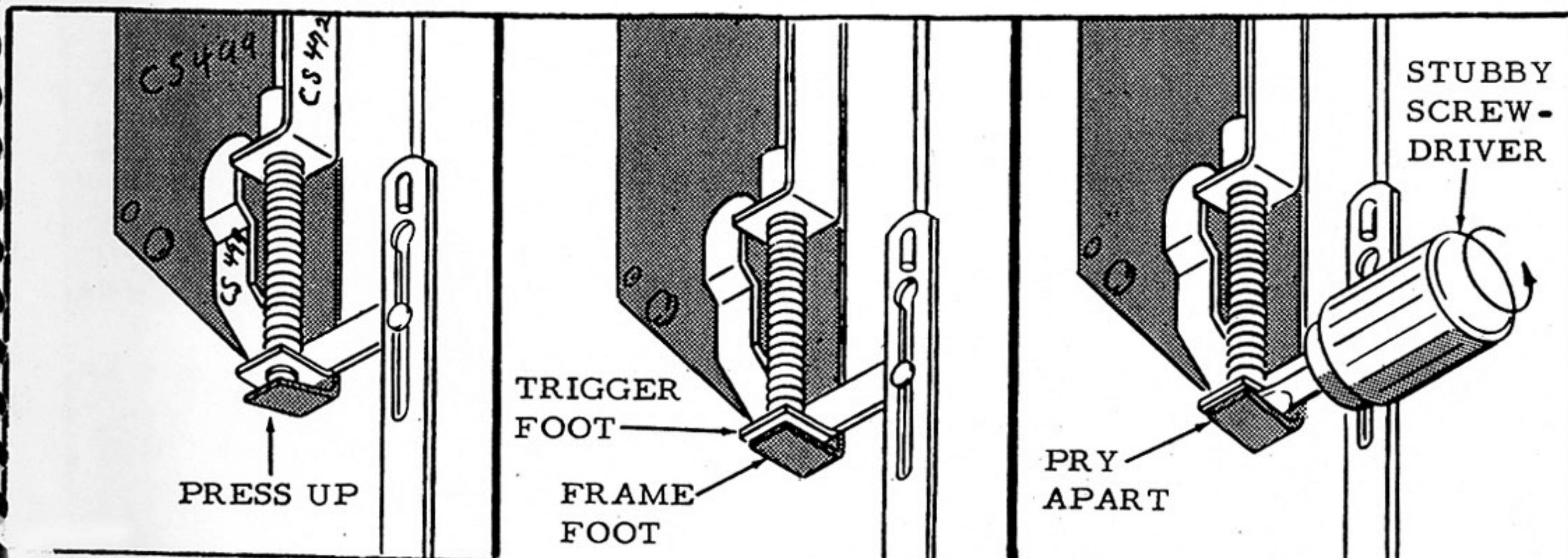

Drawing A

Drawing B

Drawing C

IF ARM TURNS SLOW, OVERSHOTS STOP, DOES NOT TURN AT ALL OR DOES NOT THROW MISSILE, DISASSEMBLE AS FOLLOWS:

- A. Remove Hub Nut by twisting off with pliers. (This nut cannot be reused if damaged)
- B. Slide off Arm and check following:
 1. If Lever Spring has jumped plastic stop- reset Lever Spring in correct position (as shown in drawing "A")
 2. Push Lever up approximately 1/4 inch and release-Lever should snap back.
 3. If Lever sticks and cannot be freed-use replacement Arm.
 4. If Lever has an excessive amount of wobble- use replacement Arm.
- C. Slide off Plastic Collar (note position of collar in relation to square shaft and Cam-spring assembly, as it must be replaced in the same position)
- D. Slide off Cam-spring assembly (note position of item to square shaft and Robot as it must be replaced in the same position), and check following:
 1. If Spring is distorted- replace with a new assembly (check to make sure you replace a right Cam-spring on the right side / a left Cam-spring on the left side. Cam-springs are identified R and L)
 2. If Spring has jumped small posts- replace with new assembly.
 3. If Cam-spring is in good condition- reuse, as Arm may have become dis-oriented during use.

REASSEMBLY

- A. Position Cam-spring assembly on square shaft in the same position as it came off otherwise Arms will not be alternately synchronized.
- B. Position Plastic Collar on shaft in same position as it came off in relation to Cam-spring assembly. (Flat on inside of collar must be next to and parallel to raised inner rivet head as shown by dotted line on drawing "B")
- C. Position Arm- SO THAT LOOP OF CAM-SPRING ASSEMBLY HOOKS ON TO THE RIGID (SHORT) METAL POST OF THE ARM (not on movable Lever posts) THEN PUSH IN ARM AS FAR AS IT WILL GO. (see drawing "C") To test- take pliers and turn shaft until arm is activated. (turn clockwise on right side/ counterclockwise on left side)
- D. Replace Hub Nut by lining up flats inside the nut with the flats on the square shaft and press on. (tap Hub Nut lightly with a hammer, if necessary) Arm should have 1/16 inch end play.
- E. If condition is not corrected, refer to section below

IF MOTOR IS RUNNING AND A "CLICKING" NOISE IS HEARD IN THE "FIRE MISSILE" POSITION AND ARMS ARE NOT TURNING, check to see if DRIVE CHAIN is loose as follows:

- A. Remove Left Inspection Panel.
- B. Operate Robot in "FIRE MISSILE" position. If chain slips, insert Tension Clip as follows:
 1. Press Tension Clip on to hub of Chain Sprocket until it snaps into position as shown in drawing "A". (Ears on clip must face center of Robot)
 2. Twist "ears" onto chains so they set up a tension as shown in drawing "B".
 3. Operate Robot in "FIRE MISSILE" position. Arms should turn.
 4. Replace Inspection Panel

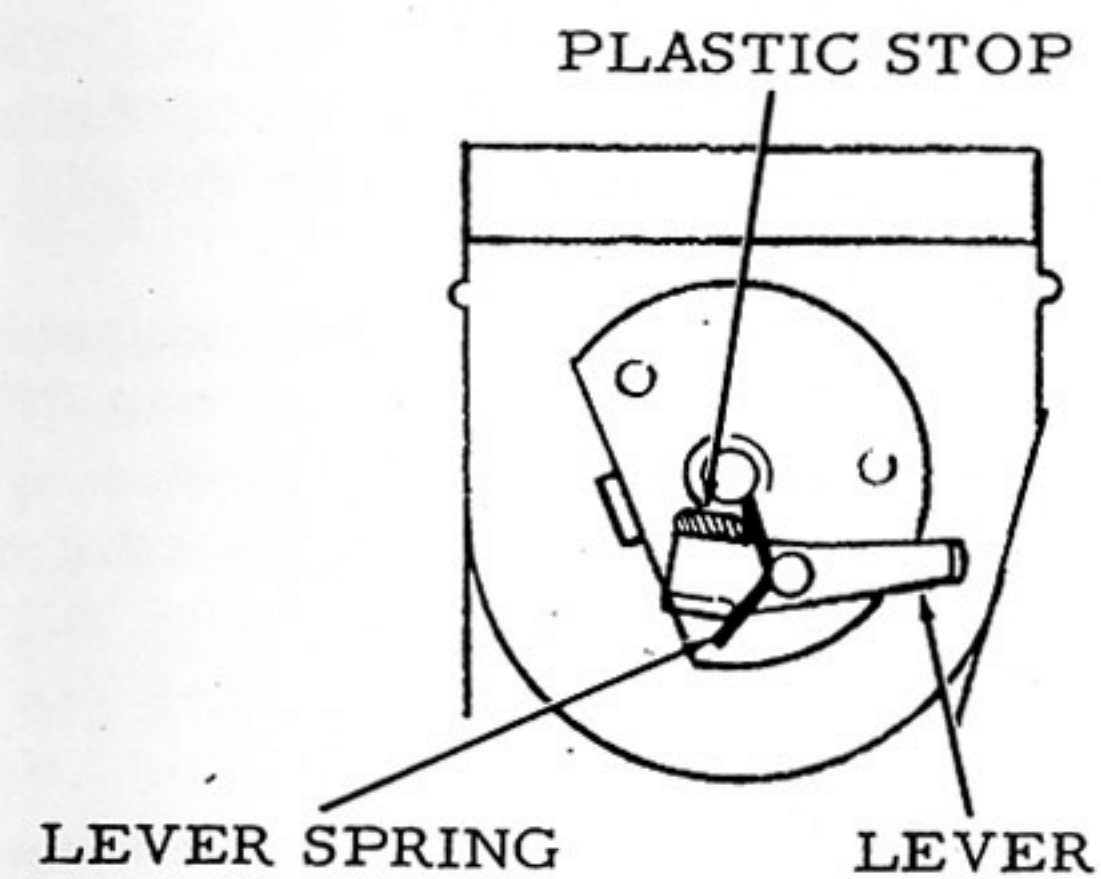

Drawing A

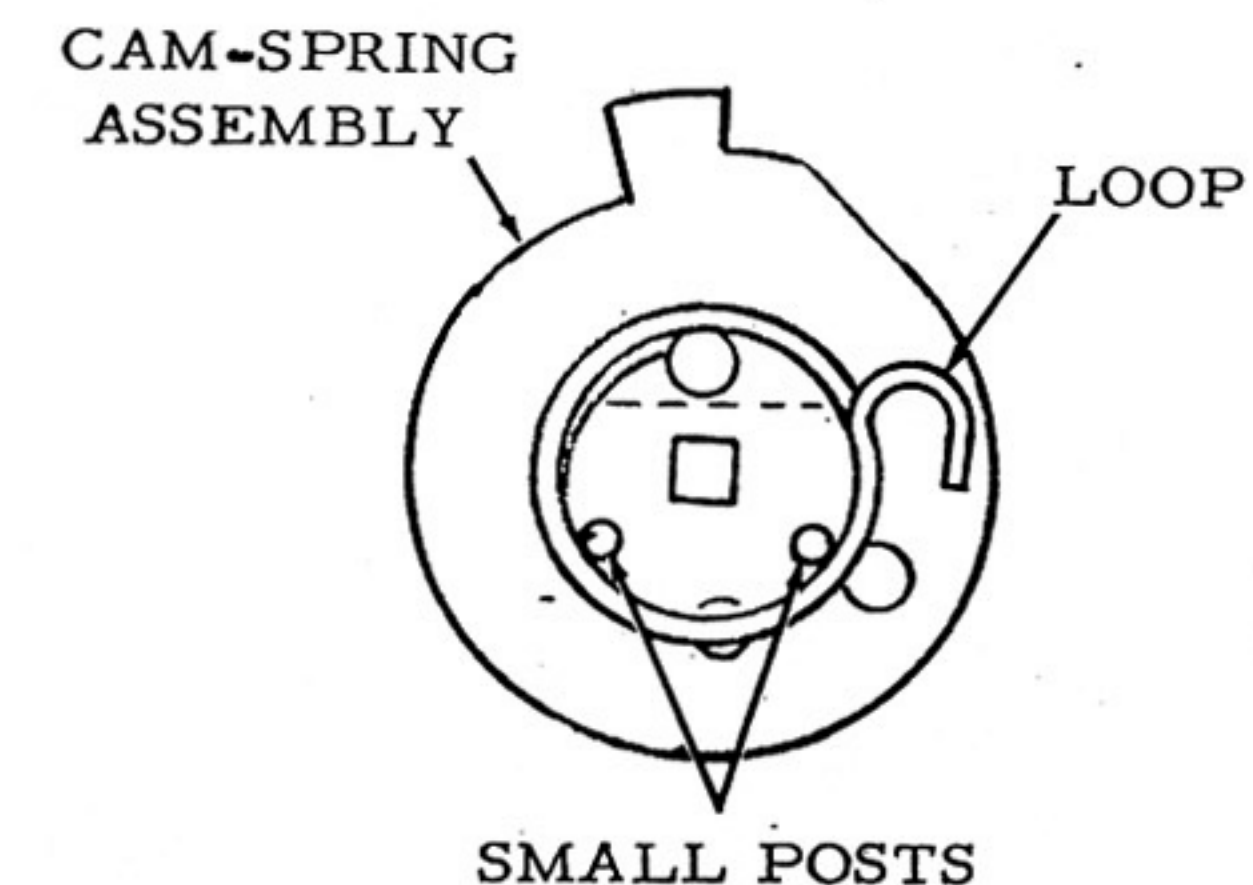

Drawing B

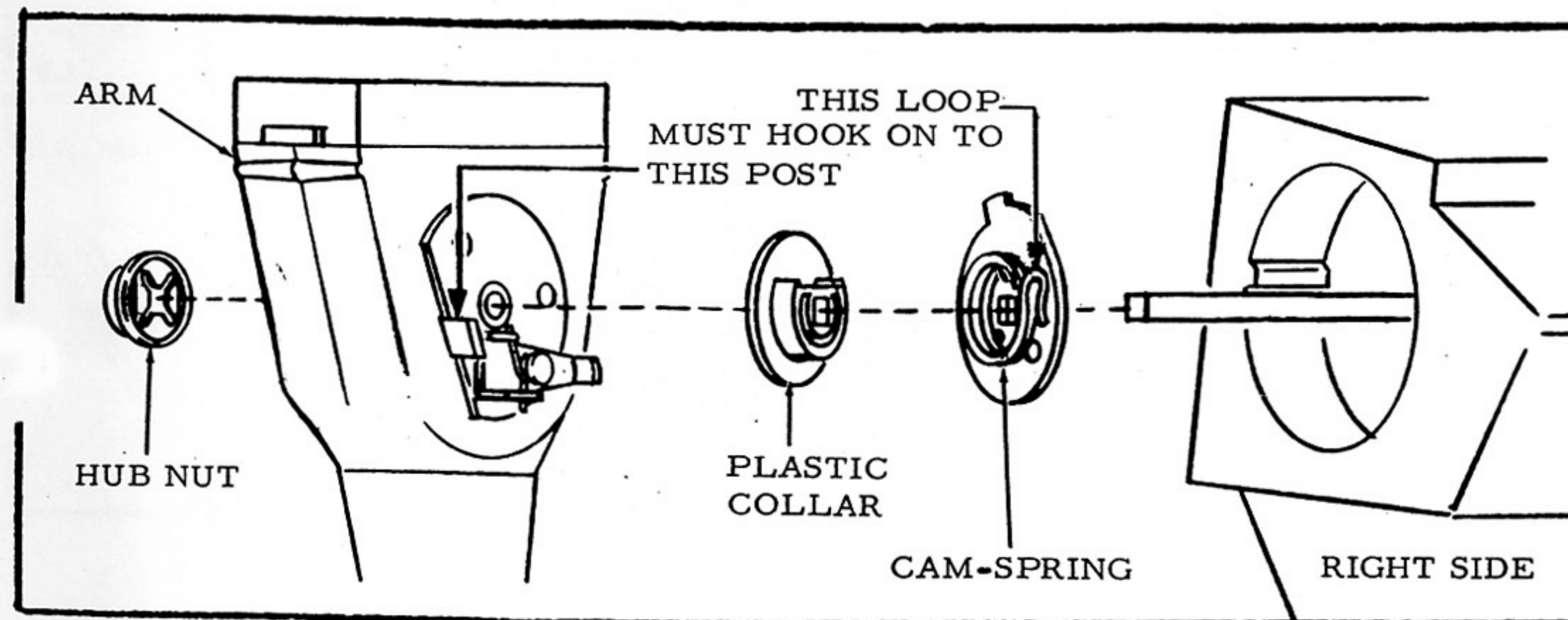

Drawing C

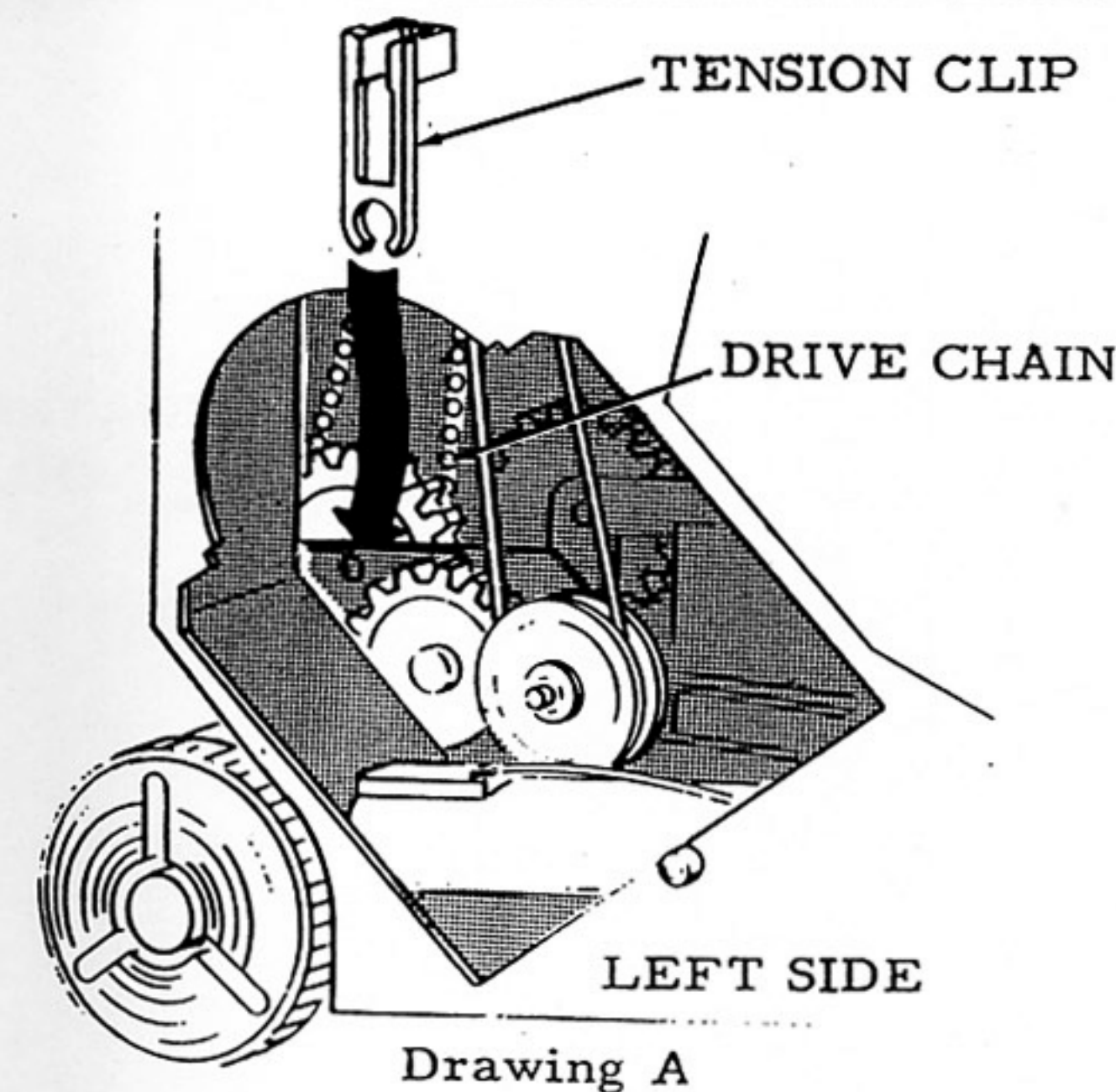

Drawing A

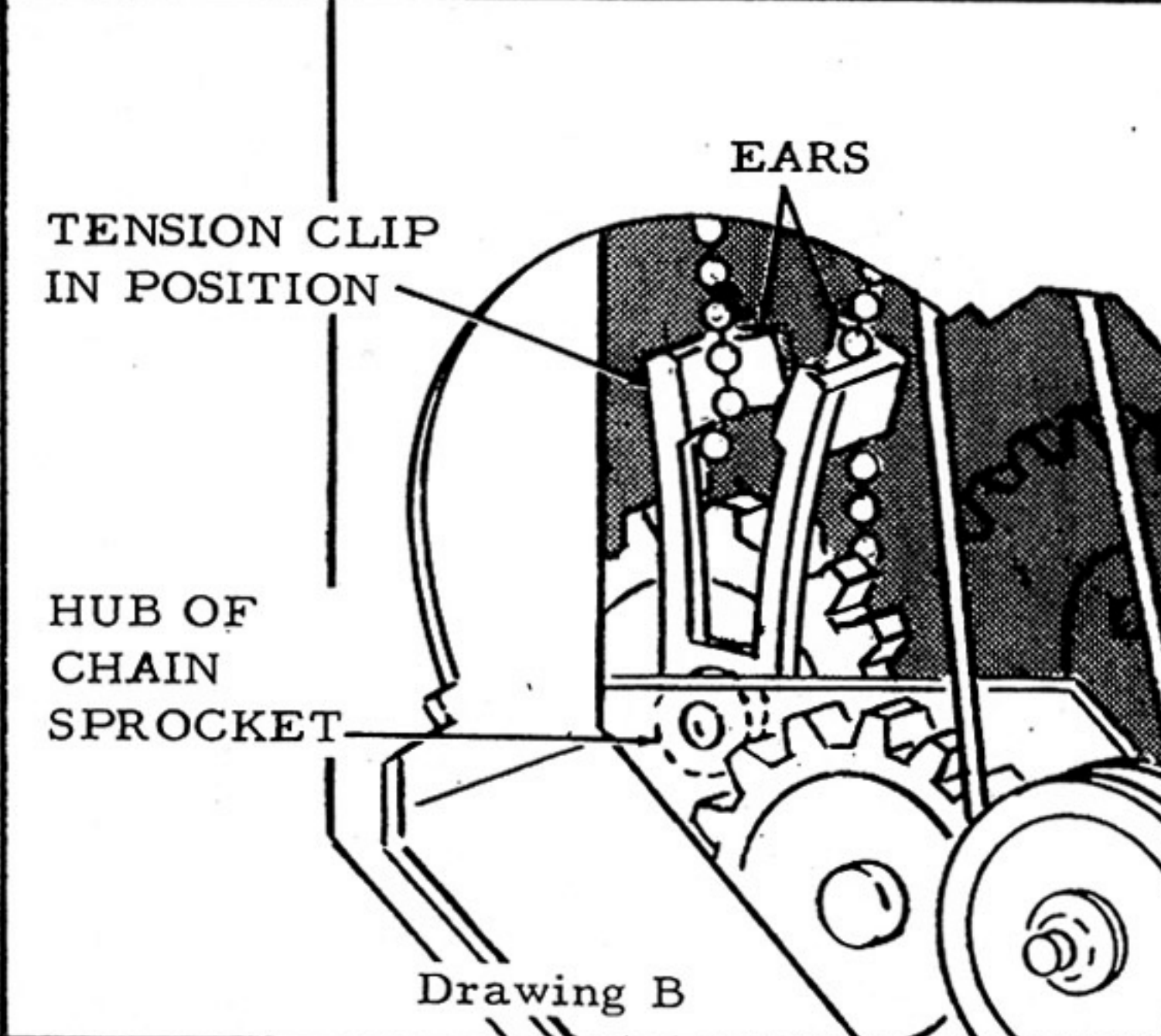

Drawing B

IF ROBOT DOES NOT TURN OR MOVE AS IT SHOULD, DISASSEMBLE AS FOLLOWS:

A. Test spring tension of each wheel by grabbing wheels firmly and pulling away from Robot. If wheels pull away with some difficulty, spring tension is O.K. If wheels pull away very easy, disassemble as follows:

1. Remove Wheel Hub by inserting a screwdriver under the inner hub and pressing out as shown in drawing "A".
2. Tap Nut on the shaft (as shown by arrows in drawing "B") toward the center of the Robot until there is approximately 3/8 inch clearance between washer under the nut and the ribs in the wheel. (recheck spring tension as noted in Step 1)

REASSEMBLY

A. Place old Hub (if not damaged) on shaft and tap into position.

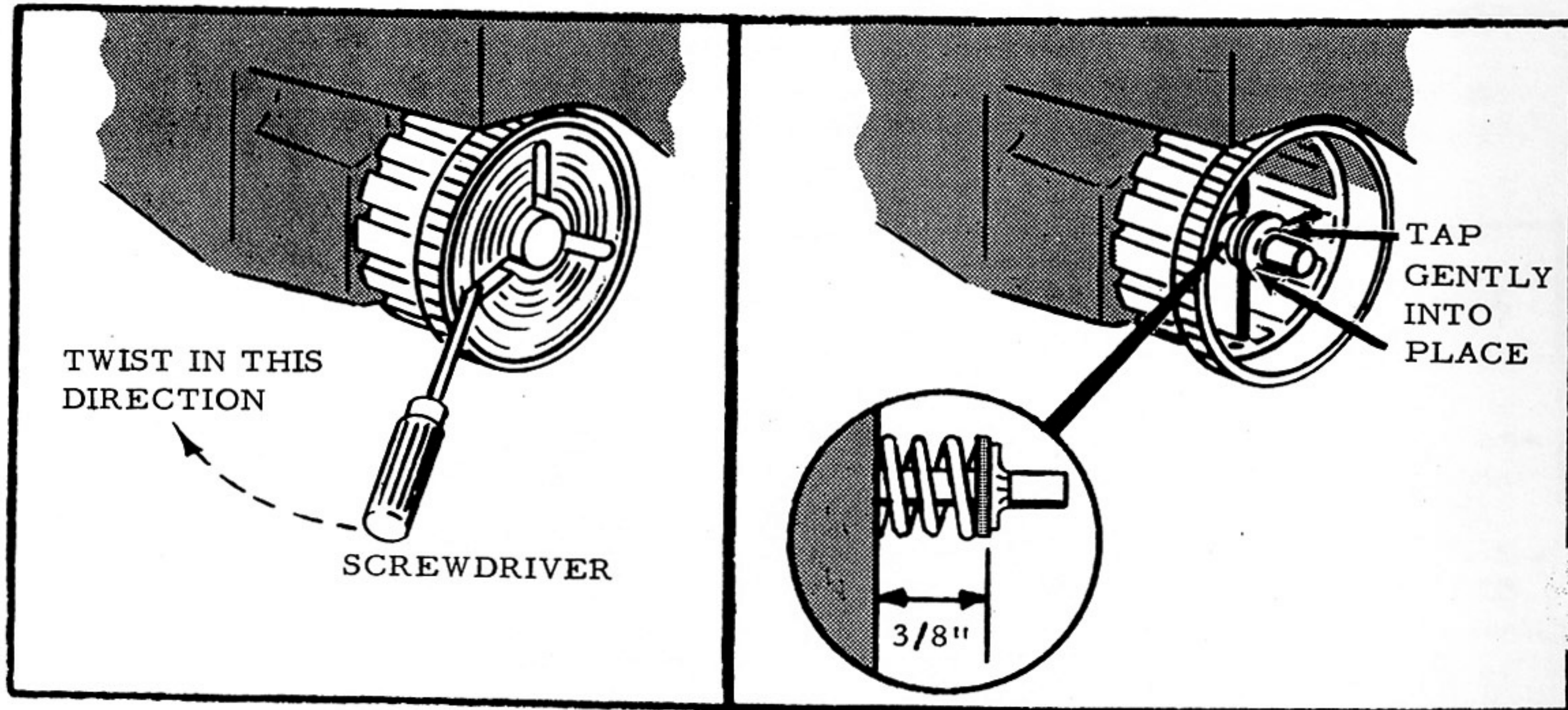

Drawing A

Drawing B

DIRECTIONS FOR INSTALLING NEW ROBOT COMMANDO CONTROL CABLE

IMPORTANT: BE SURE BATTERIES ARE NEW. THEY MUST FACE IN THE DIRECTION AS SHOWN BY ARROWS ON BASE OF ROBOT.

A. If there is a cable attached to Robot, place Control Knob of the Control Handle in the "Turn Left" position. Remove cable by backing off SCREW a few turns, sliding METAL PLATE out from under TAB and twisting metal plate out of the way as shown. Then spread SLOT apart as shown by heavy arrows and lift cable out of base. The CONTACT PLUG and LOOP should lift out without any trouble.

B. Install new CABLE by:

1. Spreading SLOT apart as shown by heavy arrows and placing CABLE into SLOT with CONTACT PLUG facing down as shown.
2. Place LOOP on POST. (Post must be in upper opening)
3. Press CONTACT PLUG over the two metal PRONGS and push all the way down until it will go no further.
4. Place METAL PLATE over CONTACT PLUG and under TAB. Then re-tighten SCREW all the way.

